

## MULSANNE B FITTING INSTRUCTIONS

### LOTUS: Std and A340/ GM:931 TYPE, DRIVER SIDE SUB-FRAMES

### WITH NYLON SPACER KIT (R01SI0087)



Mulsanne B shown with side mount subframe  
Also shown with R01SI0007 seat cushion trim kit.

## INTRODUCTION

Mulsanne B is a single skin carbon/composite seat developed for applications where light weight and low cost are of priority. The front of the seat has a high quality Auto-clave moulded gloss finish.

This performance seat has been specifically developed for the Lotus Elise S1/S2/111R/Federal, Exige S1/S2, 340R and VX/VXR220 range of cars with tailored fitting kits to suit each model (when ordering you should state Lotus/Vauxhall model and chassis VIN no). Due to the compact dimensions of the seat it has also proven to be an ideal fitment to vehicles with limited cockpit space.

## **WARNING, MOTORSPORT OR DRIVING CAN BE DANGEROUS RESULTING IN DEATH OR PERSONAL INJURY.**

## **READ OUR FITTING INSTRUCTIONS CAREFULLY**

This article is sold without warranty expressed or implied. No warranty or representation is made as to this product's ability to protect the user from injury or death. The user assumes that risk. The effectiveness, warranty and longevity of this equipment are directly related to the manner in which it is INSTALLED, USED, and/or MAINTAINED. THE USER ASSUMES THE RISK.

**FITMENT OF REVERIE PRODUCTS TO AUTOMOBILES THAT ARE SUBJECT TO A MANUFACTURER'S WARRANTY MAY VOID THE MANUFACTURER'S WARRANTY AND THE VEHICLES ABILITY TO MEET EMISSION OR OTHER TRANSPORT REGULATIONS.**

By purchasing this product and opening the packaging, purchasers expressly acknowledge, understand and agree that they take, select and purchase these REVERIE products from REVERIE, its affiliates, distributors, and agents (collectively, REVERIE) "as is" and "with all faults".

The entire risk as to the quality and performance of these REVERIE parts is with the purchasers. Should the goods prove defective following their purchase; the purchasers assume the entire cost for all necessary servicing or repair or any resulting liability. Working on your car can be a dangerous activity. If you are unsure of what you are doing, please leave mechanical or Safety critical work to a skilled mechanic.

We take no responsibility for the incorrect use and / or installation of REVERIE products.

[WWW.REVERIE.LTD.UK](http://WWW.REVERIE.LTD.UK)

# INDEX

## PAGE

<b>3</b>	<b>UV-PROTECTION</b>
<b>3</b>	<b>PART NUMBER IDENTIFICATION</b>
<b>4</b>	<b>LOTUS: SUB-FRAME GENERAL INFORMATION.</b>
<b>5</b>	<b>FITTING KIT CONTENTS</b>
<b>6-8</b>	<b>FITTING INSTRUCTIONS</b>

## Mulsanne B Fitment

### Drivers Seat Fitment Requirements:

Mulsanne B Seat, Nylon spacer Kit ([R01SI0087](#)) - Required for:

All Standard Lotus and VX220 seat sub-frames require the Nylon spacer kit for installation of the Mulsanne B seat. regardless of 3-point seat belt or 3/4/5/6-point harness

Mulsanne B Seat, Drives Side Conversion Kit ([R01SI0081](#)-RHD, [R01SI0083](#)-LHD) – Required for:

Elise S1 (std), Elise S2 , Elise 111R , Exige S1 (std/sport), Exige S2 (std/sport) when using 3/4/5/6-point harnesses.

### Passenger Seat Fitment Requirement: ([R01SI0085](#)-RHD, [R01SI0086](#)-LHD)

Our Mulsanne B Seat Requires the Reverie Mulsanne B Passenger Sub-frame Kit to fit in the passenger seat position for all vehicles. Compatible with both Std 3-point seat belt and 3/4/5/6-point harnesses.

## UV-PROTECTION

Please Note Epoxy Pre-preg products are not UV stable. Texallium products are particularly liable and can yellow in only 2 – 6 weeks. The epoxy resin will ‘yellow’ with prolonged exposure to UV radiation and material strength properties will slowly deteriorate. We recommend exterior products or those exposed to constant UV are either colour painted or at least Lacquered. We use predominately 2K car lacquers of medium solids, the DBS range has been found very suitable, although people have had equally good results with Urethanes varnishes and epoxy clear coats.

The surface should be sanded with 180, 240 then 320 grit and a cleaning solvent used to remove grease or dirt prior to paint application. Several coats may be required (normally 3 to 4 light coats) to avoid pin-holing, common with painting composite products. Pin holes may be dubbed in carefully with a brush, then wet flatted for a final application of 3 thin coats. **Let air dry only**, you may stove the paint at 70’c once fully air dried.

## PART NUMBER IDENTIFICATION

Reverie part numbers are in red eg **R01SI6002A**

Lotus part numbers are in green eg **A111V0012J**

# LOTUS SUB-FRAME GENERAL INFORMATION.

The only requirement to fit the Mulsanne B seat into the standard Drivers Sub-frame is the addition of the Nylon Spacer Kit **R01SI0087**.

The owner should refer to the MSA blue book for the correct instillation of harnesses for competition.

## Part Numbers

### 340R/Exige S1 sport

### VXR 220

RHD **A340V0009J** Lotus Adjustable driver's side

LHD **A340V0010J** Lotus Adjustable driver's side

RHD **93184421** GM Adjustable driver's side

A340 type sub frames shown, the \* insert shows the outside of the Elise S1/S2 Exige S1 C111 type sub-frames having a single shear bracket without facility for lap belt anchorage.

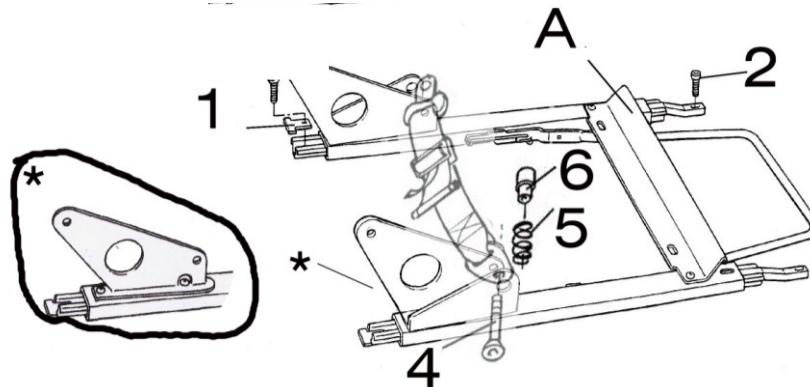

Sliding or fixed lotus A340 type sub frames are available from a lotus dealer if required.

## FITTING KIT CONTENTS

### MULSANNE B TO LOTUS:A340/ GM:931 TYPE SUB-FRAMES

#### 340R, EXIGE S1 SPORT, and VXR220

Suitable for 4/5/6 point Harnesses on Road/track day cars, see MSA blue book for race cars.

**GREEN = FITTING KIT CONTENTS SUPPLIED BY ReVerie Ltd.**

**RED = RETAINED FROM OLD SEAT REMOVAL**

Drivers Side Only.

#### Rear brackets to subframe fixings

4 \* M8\*25mm button head bolts

2 \* 10mm thick bracket-to-spar nylon spacer

#### Subframe to seat fixings

##### Front

2 \* M8 \* 20mm button head bolts (12.9 spec)

2 \* 10mm thick nylon cross member spacer, 9mm bore 25mm OD

2 \* Penny washer M8

##### Side

2 \* Bolt Cap head M8 \* 10mm (12.9 spec)

2 \* Washer small M8

2 \* Bolts Lotus spec double sheer (short) 7/16" \* 38mm

2 \* Spacer springs

2 \* Spacer - Lotus spec steel double sheer 7/16"

# FITTING INSTRUCTIONS

## SEAT AND SUBFRAME REMOVAL

- A. Remove existing seats and sub frames from car by undoing the four bolts per sub frame attaching sub frames to chassis (retain bolts).
- B. Remove the seats from the sub frames by undoing the six retaining bolts, 2\*M8 bolts at the rear (discard), 2\*Lotus spec shanked 7/16" \*43mm seat belt bolts (discard), spacers (retain) and spring (retain), 2\*M8 nuts underneath front of seat (discard).

## FITTING MULSANNE SEAT TO STD SUBFRAMES (Harnesses and std seat belts)

A.

First remove the rear brackets. Place the 10mm thick spacers under the brackets and re-attach the A340 spec brackets to the sub-frame using the M8\*20 button head bolts.

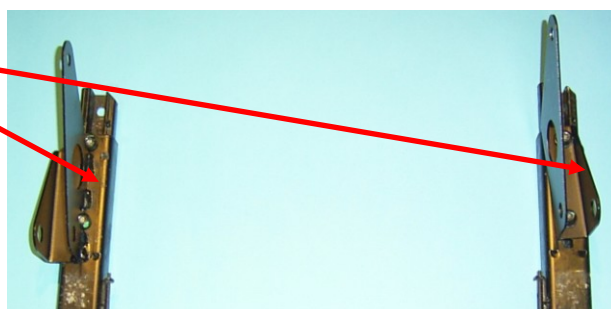

B.

Lower the subframe into the car and line up the four mounting holes with those on the subframe (see images on final page for correct holes) insert and partially tighten the four anchor bolts to keep it in place, then insert and fully tighten the cross brace bolts to ensure the subframe holds its shape. When this is complete, take out the four bolts and remove the subframe from the car.

C.

Place the seat on the sub- frame and position the two 9mm bore nylon spacers between the seat and sub-frame cross-member. Thread in the supplied M8\*20mm bolts through the small dia M8 washers, the cross brace and nylon spacer into the seat and tighten partially (you will tighten fully later) to allow the seat a little float.

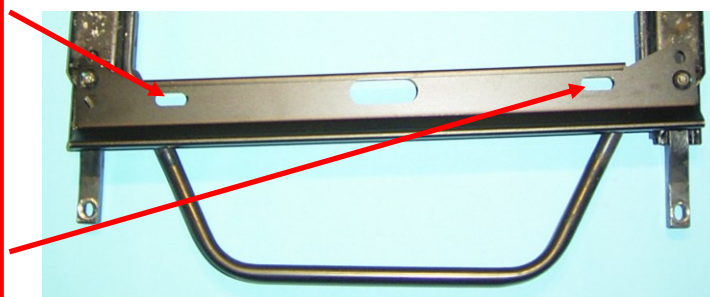

C(Cont...).

If using OEM 340R harness belts (A340U6005S) a crutch strap is included. The bolts you have just installed need to be threaded through the metal bar and partially tightened. If using another harness either 5 or 6 point then the straps should be taken through the seat and to a secure fixing on the chassis.

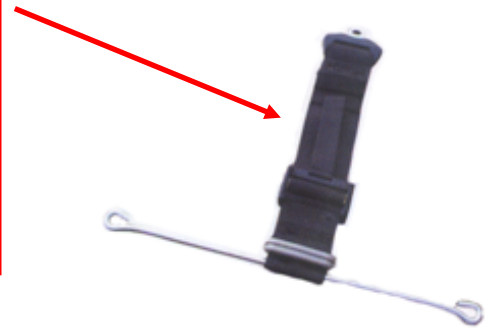

D.

Insert the provided short 7/16" bolts and retained spacers with springs and partially tighten. If you are installing a seatbelt harness, now is the time to do that too.

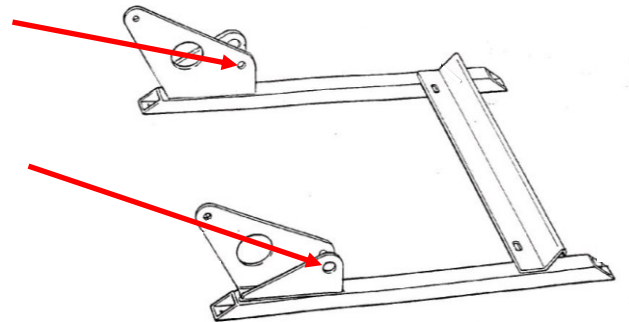

E.

Insert the two M8\*10mm bolts and washers provided and tighten. The rest of the bolts can now be tightened including the 2 M8s under the front and the 7/16" bolts on the side.

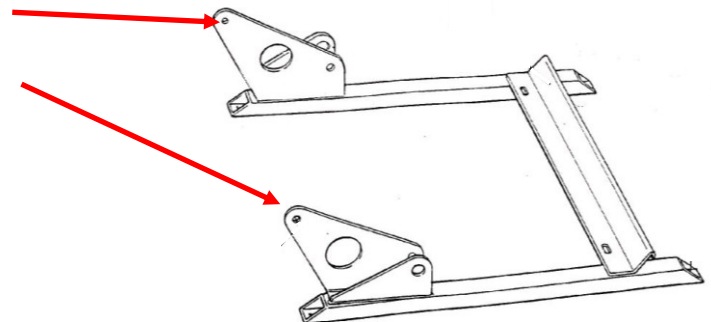

F.

The seat and sub-frame can now be reinstalled into the car, the subframe should be bolted in loosely to the chassis (using the mounting points specified on page 8) and the seat ran back and forth on the sub-frame runners several times until it runs smooth, the sub frame to chassis bolts can then be tightened. Installation is now complete.

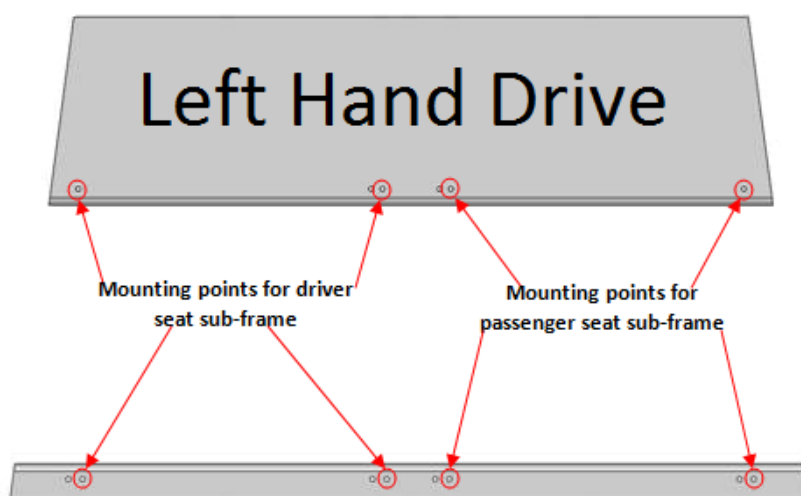
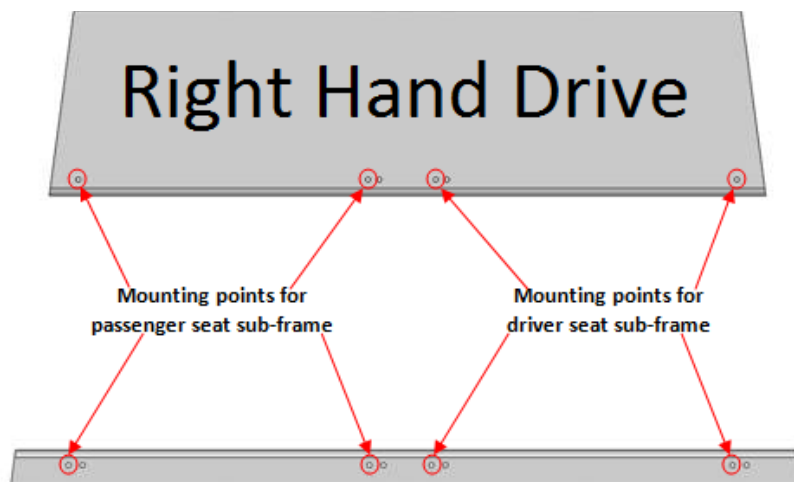

MULSANNE B FITTED TO LOTUS 340R