

MULSANNE B AND A340 SPEC PASSENGER SUB-FRAME KIT FITTING INSTRUCTIONS

A340 SPEC TYPE SUB-FRAMES



Mulsanne B shown with side mount subframe
Also shown with R01SI0007 seat cushion trim kit.

INTRODUCTION

Mulsanne B is a single skin carbon/composite seat developed for applications where light weight and low cost are of priority. The front of the seat has a high quality Auto-clave moulded gloss finish.

This performance seat has been specifically developed for the Lotus Elise S1/S2/111R/Federal, Exige S1/S2, 340R and VX/VXR220 range of cars with tailored fitting kits to suit each model (when ordering you should state Lotus/Vauxhall model and chassis VIN no). Due to the compact dimensions of the seat it has also proven to be an ideal fitment to vehicles with limited cockpit space.

WARNING, MOTORSPORT OR DRIVING CAN BE DANGEROUS RESULTING IN DEATH OR PERSONAL INJURY. READ OUR FITTING INSTRUCTIONS CAREFULLY

This article is sold without warranty expressed or implied. No warranty or representation is made as to this product's ability to protect the user from injury or death. The user assumes that risk. The effectiveness, warranty and longevity of this equipment are directly related to the manner in which it is INSTALLED, USED, and/or MAINTAINED. THE USER ASSUMES THE RISK. Fitment of REVERIE PRODUCTS TO AUTOMOBILES THAT ARE SUBJECT TO A MANUFACTURER'S WARRANTY MAY VOID THE MANUFACTURER'S WARRANTY AND THE VEHICLES ABILITY TO MEET EMISSION OR OTHER TRANSPORT REGULATIONS. By purchasing this product and opening the packaging, purchasers expressly acknowledge, understand and agree that they take , select and purchase these REVERIE products from REVERIE, its affiliates, distributors, and agents (collectively, REVERIE) "as is" and "with all faults".

The entire risk as to the quality and performance of these REVERIE parts is with the purchasers. Should the goods prove defective following their purchase; the purchasers assume the entire cost for all necessary servicing or repair or any resulting liability. Working on your car can be a dangerous activity. If you are unsure of what you are doing, please leave mechanical or Safety critical work to a skilled mechanic.

We take no responsibility for the incorrect use and / or installation of REVERIE products.

WWW.REVERIE.LTD.UK

INDEX

PAGE

3	UV-PROTECTION
3	PART NUMBER IDENTIFICATION
4	REVERIE A340 TYPE SUB-FRAMES GENERAL INFORMATION
5	FITTING KIT CONTENTS
6	FITTING INSTRUCTIONS

UV-PROTECTION

Please Note Epoxy Pre-preg products are not UV stable. Texallium products are particularly liable and can yellow in only 2 – 6 weeks. The epoxy resin will 'yellow' with prolonged exposure to UV radiation and material strength properties will slowly deteriorate. We recommend exterior products or those exposed to constant UV are either colour painted or at least Lacquered. We use predominately 2K car lacquers of medium solids, the DBS range has been found very suitable, although people have had equally good results with Urethanes varnishes and epoxy clear coats.

The surface should be sanded with 180, 240 then 320 grit and a cleaning solvent used to remove grease or dirt prior to paint application. Several coats may be required (normally 3 to 4 light coats) to avoid pin-holing, common with painting composite products. Pin holes may be dubbed in carefully with a brush, then wet flatted for a final application of 3 thin coats. **Let air dry only**, you may stove the paint at 70'c once fully air dried.

PART NUMBER IDENTIFICATION

Reverie part numbers are in red eg **R01SI6002A**

Lotus part numbers are in green eg **A111V0012J**

Vauxhall part numbers are in blue eg **9197354**

LOTUS A340 TYPE SUB-FRAMES GENERAL INFORMATION

ReVerie A340 spec Passenger side sub-frame conversion kit. The GM:919/LOTUS:A122 type passenger side sub-frame's need to be replaced with a Lotus A340 type passenger side sub frame. A full passenger side A340 sub-frame kit is available from ReVerie Ltd.

The owner should refer to the MSA blue book for the correct installation of harnesses for competition.

GM:919 and LOTUS:C116/A122 to A340 spec sub-frame conversion kit

Passenger side 340R sub-frame kit

RHD **R01SI0085A**

LHD **R01SI0086A**



FITTING KIT CONTENTS

REVERIE A340 SPEC PASSENGER SUB-FRAME KIT

Suitable for 3/4/5/6 point Harnesses on Road/track day cars, see MSA blue book for race cars.

Passenger side (340R sub-frame kit)

Rear

2 * Bolt Cap head M8 * 12mm (12.9 spec)

2 * Washer penny M8

Anchor

2 * Bolt Lotus spec double sheer (short) 7/16 * 38mm (one in kit) (R01SI6037)

2 * Spacer Lotus spec steel double sheer 7/16" (one in kit) (R01SI6047)

2 * Spacer Spring (one in kit) (R01SI6168)

2 * 8mm thick nylon bracket to sub-frame spacers (R01SI6168)

4 * Bolt Button head M8 * 20mm (12.9 spec)

Front

3 * Bolt button head M8 * 20mm (12.9 spec)

3 * Bolt button head M5 * 75mm button head

4 * Bolt cap head M8 * 12mm (12.9 spec)

2 * Washers small OD M8

2 * 8mm thick, 9mm bore nylon, seat to cross-member spacers (R01SI6167)

Subframe

1 * Outside double shear bracket (RHD=R01SI6054 LHD=R01SI6042)

1 * Inside double shear bracket (RHD=R01SI6055 LHD=R01SI6041)

1 * Sub-frame Front cross-member (R01SI6040)

1 * Sub-frame outer Rail (RHD=R01SI6058 LHD=6060)

1 * Sub-frame Inner Rail (RHD=R01SI6054 LHD=6059)

FITTING INSTRUCTIONS

LOTUS/GM SEAT AND SUB-FRAME REMOVAL

- A. Remove existing seats and sub frames from car by undoing the four bolts per sub frame attaching sub frames to chassis (retain bolts).
- B. Remove the seats from the sub frames by undoing the six retaining bolts, 2*M8 bolts at the rear (discard), 1*7/16 hex head out-side seat belt bolt and spacers (discard), 1* Lotus spec shanked short 7/16 in-side seat belt bolt (retain), spacer (retain) and spring (retain), 2* M8 nuts underneath front of seat (discard).

FITTING MULSANNE SEAT AND A340 SPEC BRKTS TO STD DRIVERS SIDE SUBFRAMES (HARNESSES AND STD SEATBELTS)

A.

Remove the outer and inner rear brackets and cross brace, retaining the bolts and washers.

B.

With the original single sheer brackets removed, place the 10mm thick Nylon spacer under the new double sheer A340 spec brackets and loosely bolt (you will tighten it later) in place using the 1x M8*20 and 3x M8*25 button head bolts provided.

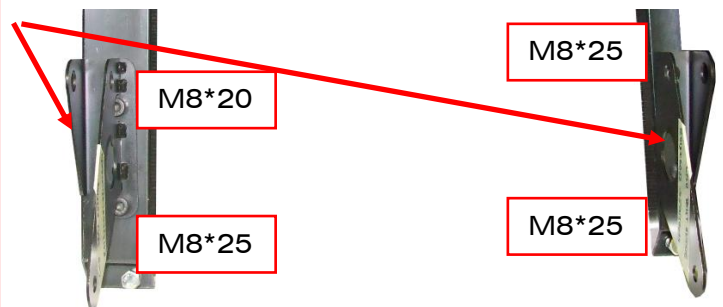

C.

Loosely bolt the A340 spec cross brace in the position shown noting which holes are used (RHD sub-frame shown, mirror fitment for LHD).



D.

Place the sub frame in the car and locate on the chassis using the diagrams on page 8 to find the correct holes for your driving configuration. Tighten the cross-member bolts to fix the subframe position and then, when it is rigid, remove the four holding bolts and take it out of the car.

E.

Place the subframe over the seat and position the two 10mm thick, 9mm bore, nylon spacers between the cross member and seat fixings. If you are installing a harness then the crutch strap goes on here too. (If you're using another harness either 5 or 6 point then the straps should be taken through the seat and to a secure fixing on the chassis. Thread in and finger tighten the two M8*20mm bolts and small dia M8 washers, leave loose for the moment to allow the seat a little float.

F.

Install into the brackets the short 7/16" bolts, springs and metal spacers. Leave loose for the moment to allow the seat a little float. Remember to install the seat belt mounts at this point also.

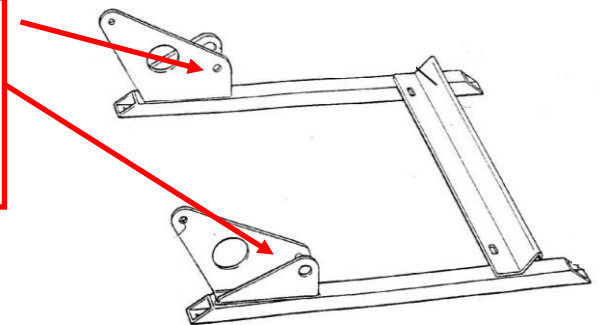

G.

Insert the two M8*12mm bolts and penny washers provided and tighten. Then tighten all other bolts, including the two M8*20mms under the front and the 7/16" bolts on the side.

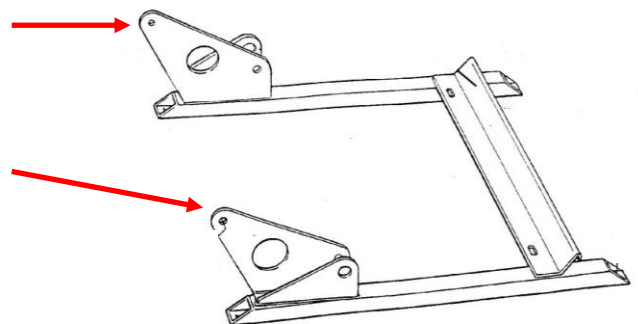

H.

The seats and sub-frames can now be reinstalled into the car and bolted to the chassis using the mounting points depicted in the diagram for your driving configuration on page 8. When all bolts are tightened and the seat is held firmly in place, installation is complete.

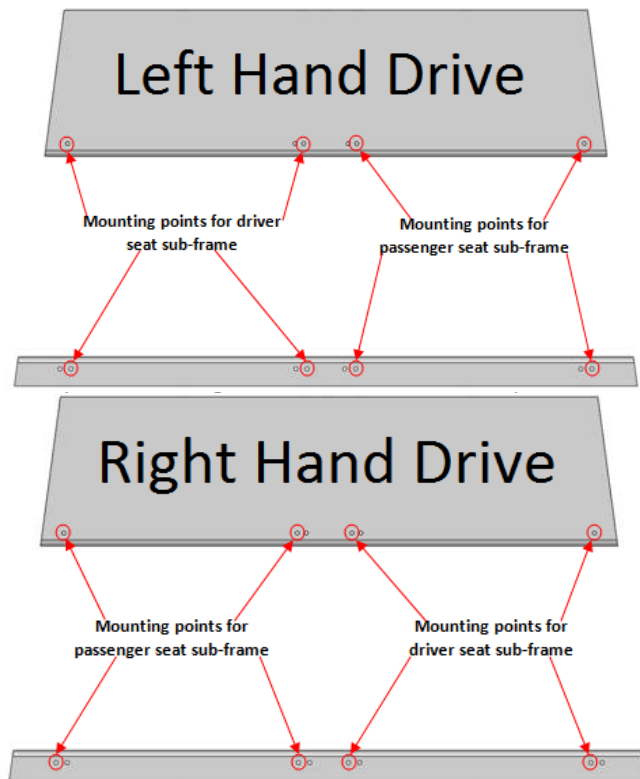

Pay close attention to which holes are used. (RHD shown, LHD is mirror fitment)



MULSANNE B FITTED TO RACING ELISE S1