

Lotus Super Sport B Single Skin (R01SI0106) To cnc Lotus Side Mount (R01SI0115) Fitting Instructions



*Super Sports B Single Skin Seat, (R01SI0106)
 Black Fia Fabric Trimmed Fia 8855-1999 Approved.*

INTRODUCTION

Super Sports B Single Skin Seat, (R01SI0106) carbon/composite seat developed for applications where light weight and low cost are of priority. The width of this seat across the mounting point areas is 440mm

WARNING, MOTORSPORT OR DRIVING CAN BE DANGEROUS RESULTING IN DEATH OR PERSONAL INJURY. READ OUR FITTING INSTRUCTIONS CAREFULLY

This article is sold without warranty expressed or implied. No warranty or representation is made as to this product's ability to protect the user from injury or death. The user assumes that risk. The effectiveness, warranty and longevity of this equipment are directly related to the manner in which it is INSTALLED, USED, and/or MAINTAINED. THE USER ASSUMES THE RISK. FITMENT OF REVERIE PRODUCTS TO AUTOMOBILES THAT ARE SUBJECT TO A MANUFACTURER'S WARRANTY MAY VOID THE MANUFACTURER'S WARRANTY AND THE VEHICLES ABILITY TO MEET EMISSION OR OTHER TRANSPORT REGULATIONS. By purchasing this product and opening the packaging, purchasers expressly acknowledge, understand and agree that they take, select and purchase these REVERIE products from REVERIE, its affiliates, distributors, and agents (collectively, REVERIE) "as is" and "with all faults".

The entire risk as to the quality and performance of these REVERIE parts is with the purchasers. Should the goods prove defective following their purchase; the purchasers assume the entire cost for all necessary servicing or repair or any resulting liability. Working on your car can be a dangerous activity. If you are unsure of what you are doing, please leave mechanical or Safety critical work to a skilled mechanic.

We take no responsibility for the incorrect use and / or installation of REVERIE products.

WWW.REVERIE.LTD.UK

INDEX

PAGE

3 UV-PROTECTION

3 SUPER SPORT S/ SKIN SIDE MOUNT FITTING KIT CONTENTS

3 PART NUMBER IDENTIFICATION

4 SIDE MOUNTS (GENERAL INFO)

5-8 FITTING INSTRUCTIONS

UV-PROTECTION

Please Note Epoxy Pre-preg products are not UV stable. Texallium products are particularly liable and can yellow in only 2 – 6 weeks. The epoxy resin will 'yellow' with prolonged exposure to UV radiation and material strength properties will slowly deteriorate. We recommend exterior products or those exposed to constant UV are either colour painted or at least Lacquered. We use predominately 2K car lacquers of medium solids, the DBS range has been found very suitable, although people have had equally good results with Urethanes varnishes and epoxy clear coats.

The surface should be sanded with 180, 240 then 320 grit and a cleaning solvent used to remove grease or dirt prior to paint application. Several coats may be required (normally 3 to 4 light coats) to avoid pin-holing, common with painting composite products. Pin holes may be dubbed in carefully with a brush, then wet flatted for a final application of 3 thin coats. **Let air dry only**, you may stove the paint at 70°C once fully air dried.

SUPER SPORT SIDE MOUNT FITTING KIT CONTENTS

4 * bolts Cap head M8 * 12mm

4 * washers Penny M8

SUBFRAMES PURCHASE SEPARATELY:

R01SI0115 Pair Lotus cnc sub frames containing below:

R01SI0113 RH Lotus cnc sub frame

R01SI0114 LH Lotus cnc sub frame

OR

R01SI0111 Pair Universal cnc sub frames containing below:

R01SI0109 LH Universal cnc sub frame

R01SI0110 RH Universal cnc sub frame

SIDE MOUNTS (ALL VEHICLE TYPES)

Super Sports B Single Skin Seat, (R01SI0106) carbon/composite seat developed for applications where light weight and low cost are of priority. The seat has been approved and tested on our billet cnc alloy side mount sub frames.

This is a universal seat and will fit any universal FIA side mount sub frame.

The seat has also been developed for the Lotus Elise and Exige S1,S2,S3, 2-eleven and 340R range of cars. and will require the FIA specification CNC'd Precision Alloy Lotus fitment Seat Sub frame

The Single skin seat version will only fit Lotus driver's side.



Below a view showing seat fitted to mounts in Lotus chassis on Drivers side (UK)

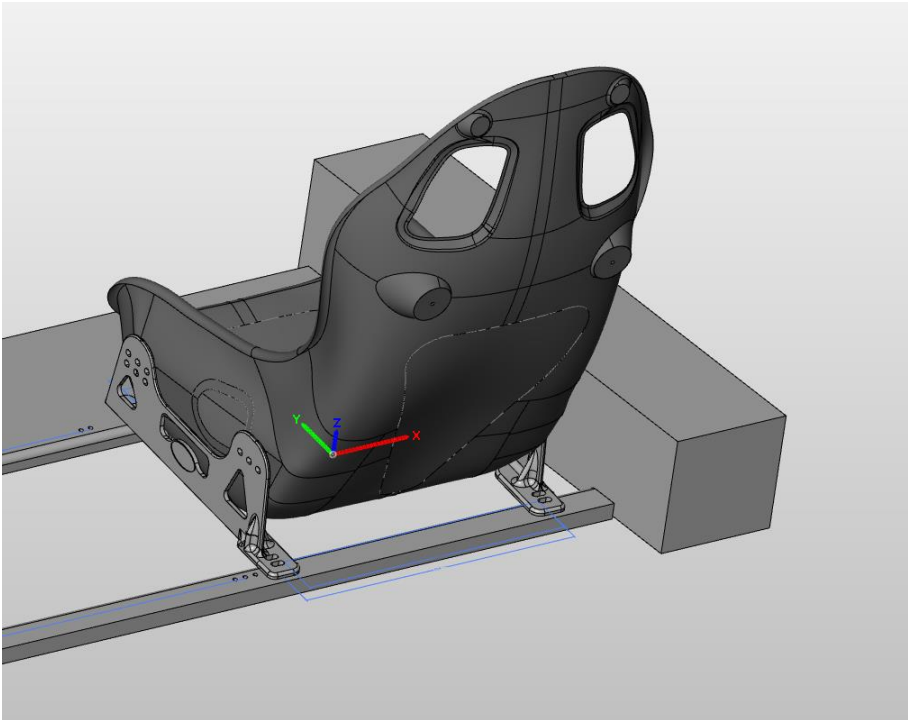

LOTUS FITTING INSTRUCTIONS



When fitting,

1: bolt sub frames to the seat using the M8 x 12mm bolts and washers provided, best to start in the positions shown above, though you may wish to adjust rake etc.

The seat sub frame bolts on the inner centre tunnel side **should only be tightened** once the sub frame has been fitted to the floor pan and tightened.

2: For RHS of Car, position seat and subframe over holes and locate all bolts then tighten sub frame to floor pan (see below). Twin skin is shown

sub frames with correct spacing showing the floor plan holes below Front 386MM (A) Back 403MM (B)

www.reverie.ltd.uk

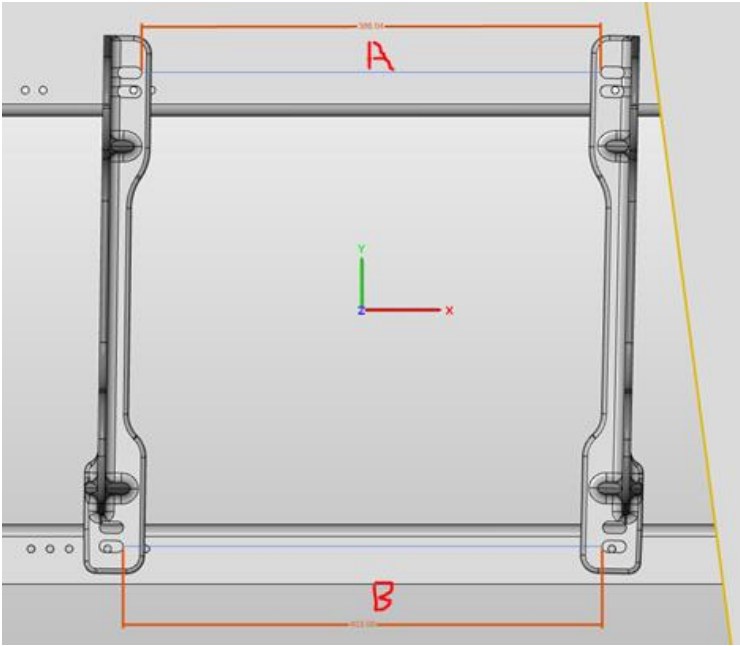

Floor plan hole centre to hole centre Front 405MM Back 424MM

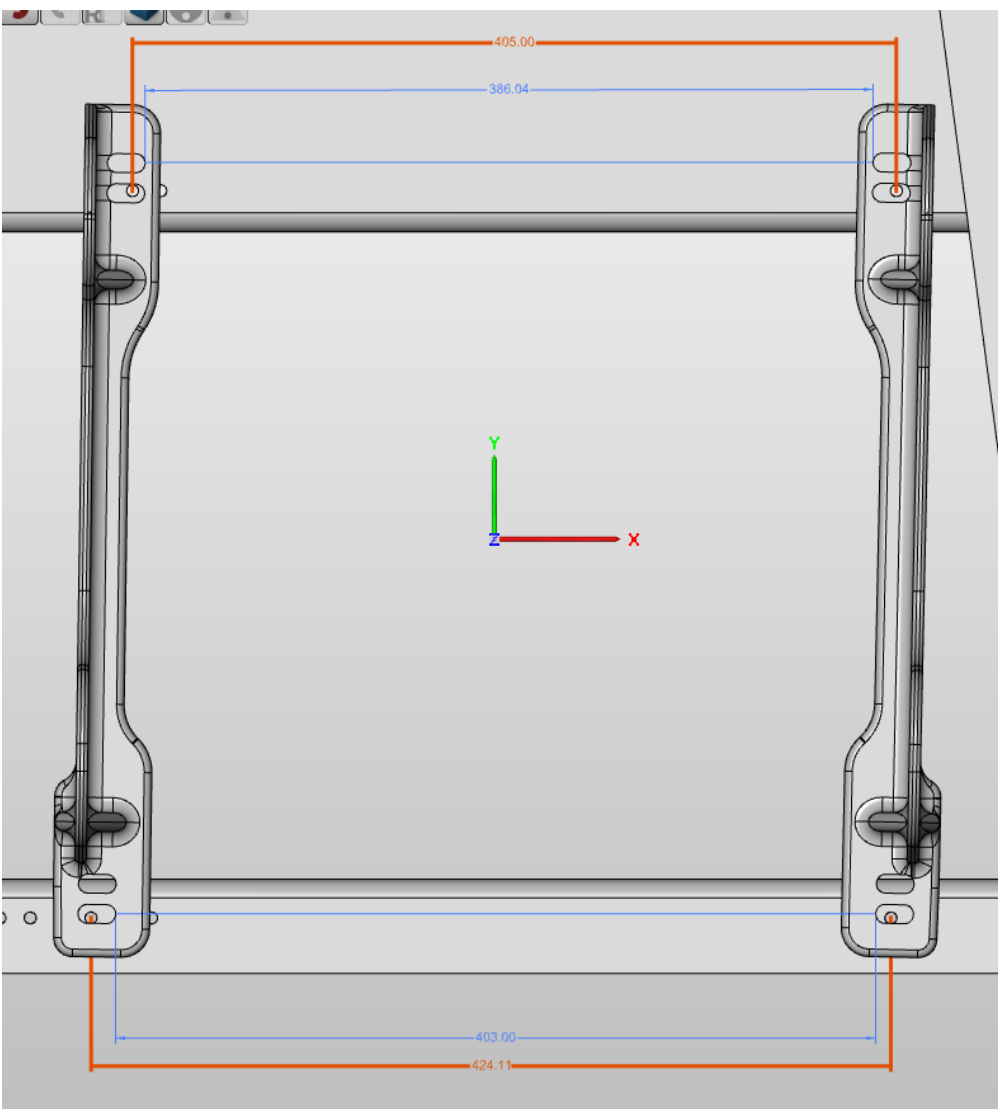

3. For LHS of Car, position seat and sub frame over holes and locate all bolts then tighten sub frame to floor pan. (See below) Single skin is shown,

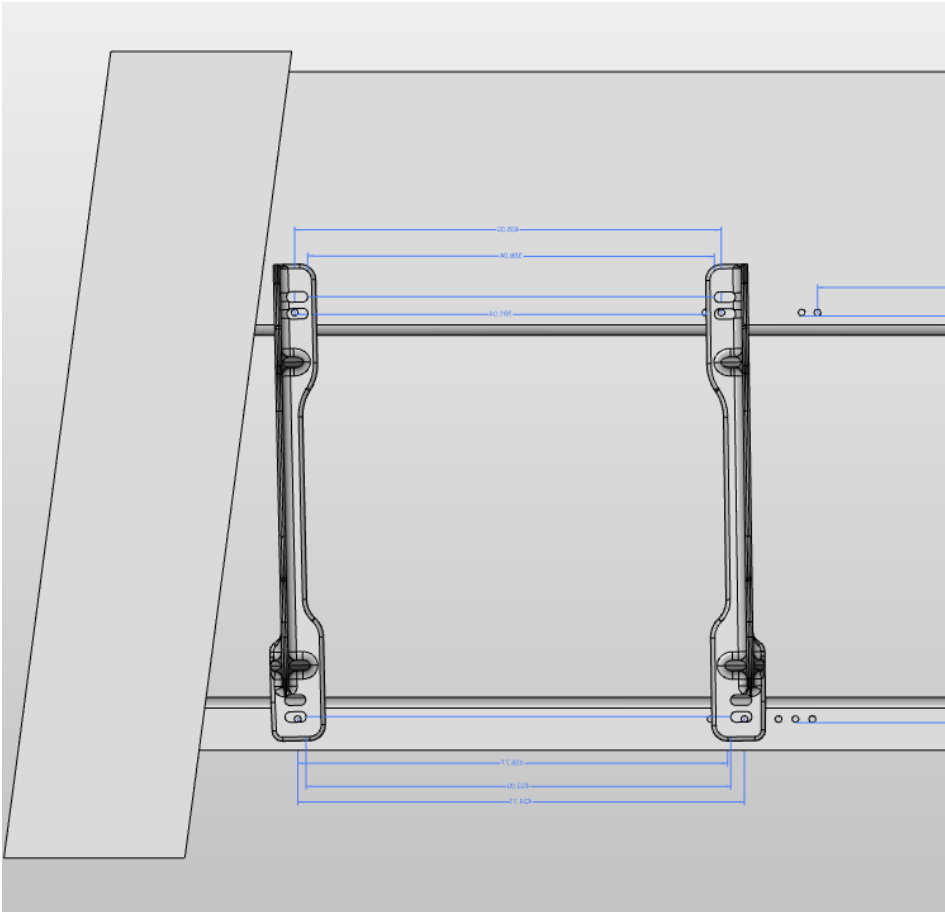

4: Then tighten the 2x bolts from the subframe to the seat on the centre tunnel side.



once the subframe bolted tight to the floor pan then the subframe can be tightened to the seat.

If the seat needs to be moved further back then the rear of the sub frames can be removed by cutting along the red line to allow the seat to move back.

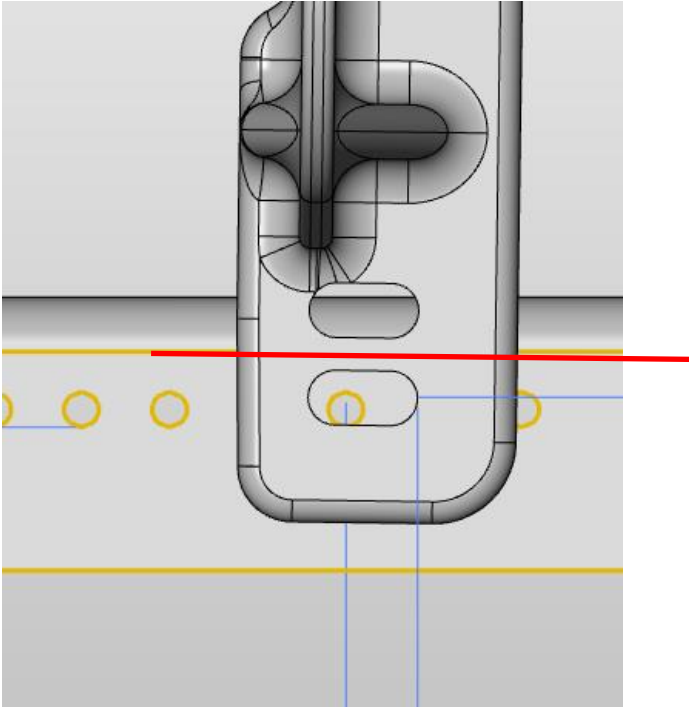

The front of seat is very close and is limited on forward movement. If you need to cut the seat to move it forwards you will invalidate your FIA

Image showing seat fitted looking at RHS of CAR and outside bracket.

