

R01SI6002 (LEFT-HAND SUBFRAME SHOWN, RIGHT-HAND SUBFRAME IS MIRRORED)

R01SI6212 (LEFT-HAND SUBFRAME SHOWN, RIGHT-HAND SUBFRAME IS MIRRORED)

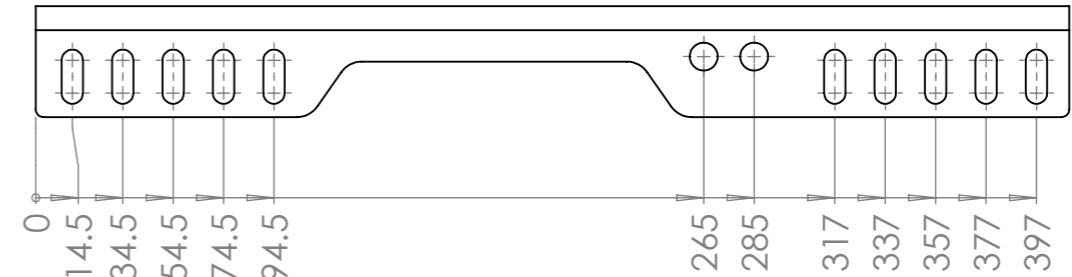

R01SI6215 (LEFT-HAND SUBFRAME SHOWN, RIGHT-HAND SUBFRAME IS MIRRORED)

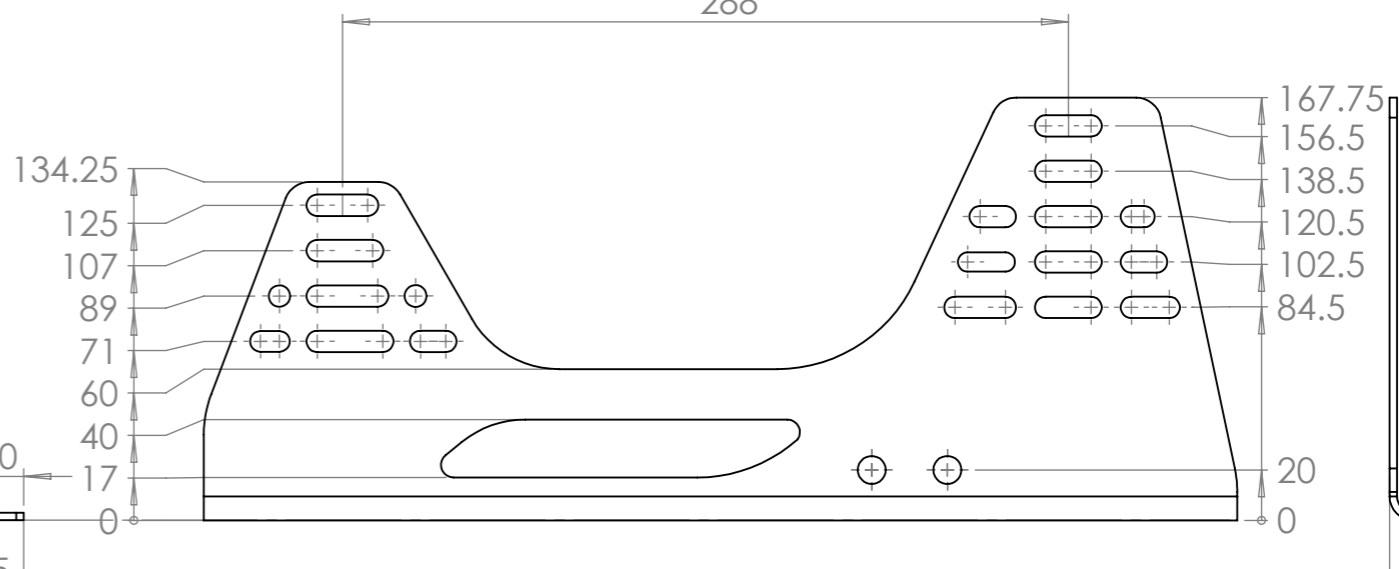
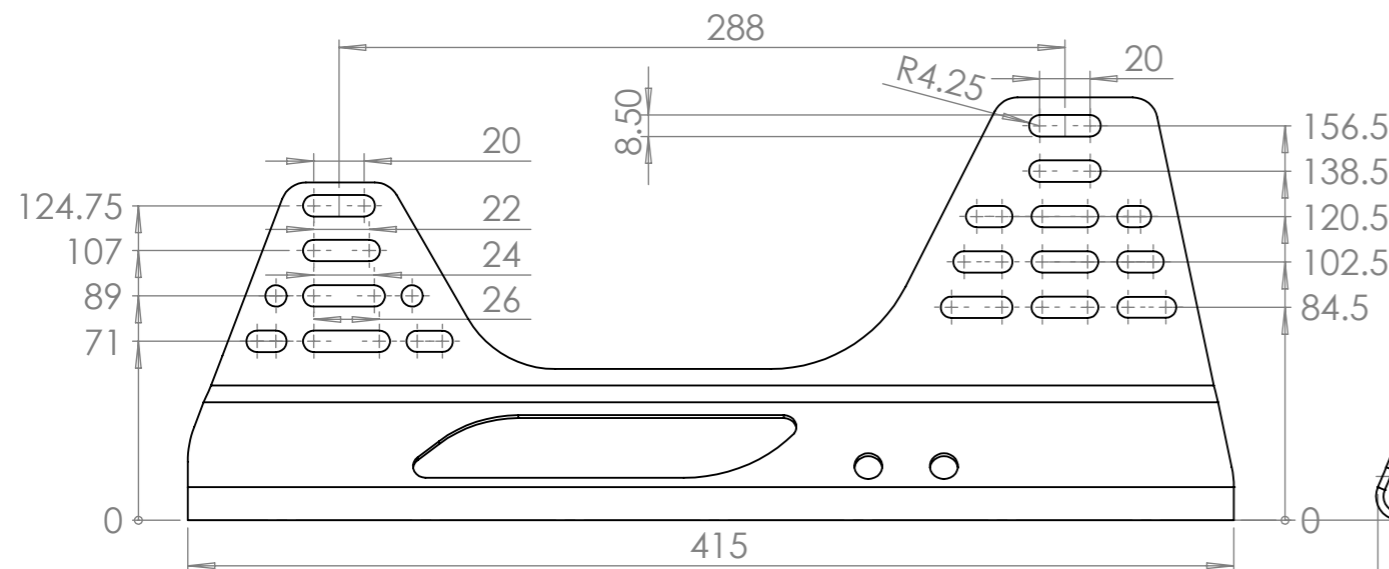
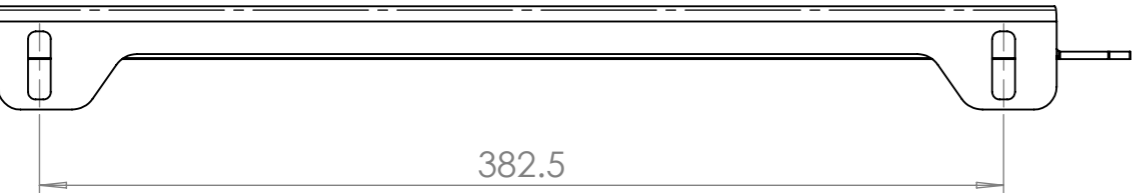
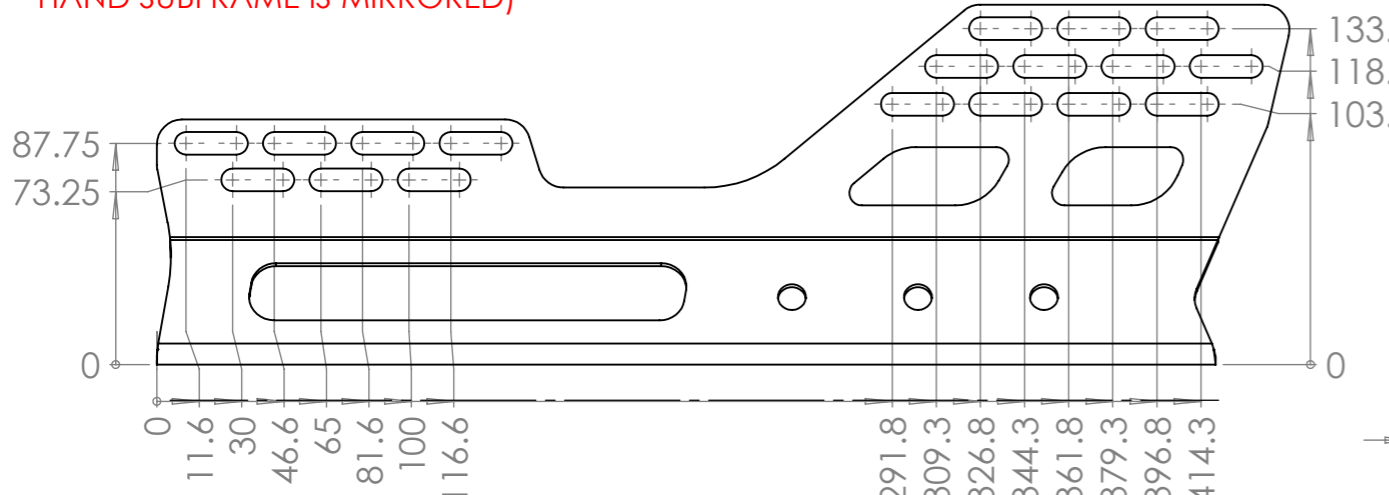

Production\Quality Sign off: Simon Farren

Costing\Specification Sign off: Simon Farren

A3 SHEET 4 OF 4

ISSUE	DESCRIPTION	INITIALS	E.C.N. No	DATE
F	**SEE SHEET TABLE			

ALL DIMENSIONS IN MILLIMETERS		
TOLERANCES (AT 20C) UNLESS OTHERWISE STATED		
NOMINAL LINEAR DIMENSIONS		
OVER-INCL	<0.00	0.00
0-200	+/- 0.50	+/- 0.15
250-1000	+/- 1.00	+/- 0.20
1000 PLUS	+/- 2.00	+/- 0.30
SURFACE FINISHES		
MILLING	N8	
TURNING	N7	
GRINDING	N6	
ANG DIMS		+/- 0.5°

REMOVE ALL BURRS AND SHARP EDGES UNLESS OTHERWISE STATED

HOLES TO BS4500 1985. THREADS TO BS3643 1981 METRIC COURSE. BSP THREADS TO BS 2779 MED FIT

THIS A DRAWING IS A PRIVATE AND CONFIDENTIAL COMMUNICATION

REVERIE

Reverie Limited
Unit 2 Chandlers Row
Colchester
Essex
CO1 2HG
01206 866663
www.reverie.ltd.uk

DRAWN	APP
JC	
DATE	30/01/2018
FINISH	SEE DRAWING
SCALE	Do Not Scale Drawing
MASS	

PART NUMBER	R01SI6002/R01SI6212/R01SI6212	
TITLE	REVERIE UNIVERSAL SUBFRAME (FLATTENED W/BEND ALLOWANCE)	
MATERIAL	SEE DRAWING	
INSPECTION LEVEL	A-1	PART QUALITY GRADE B
DRG. No.	R01SI6002/R01SI6212/R01SI6212	