

3rd ANGLE PROJ

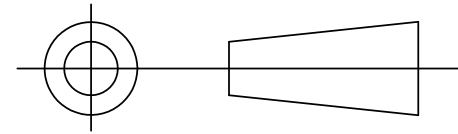

DO NOT SCALE PRINT

IF IN DOUBT ASK

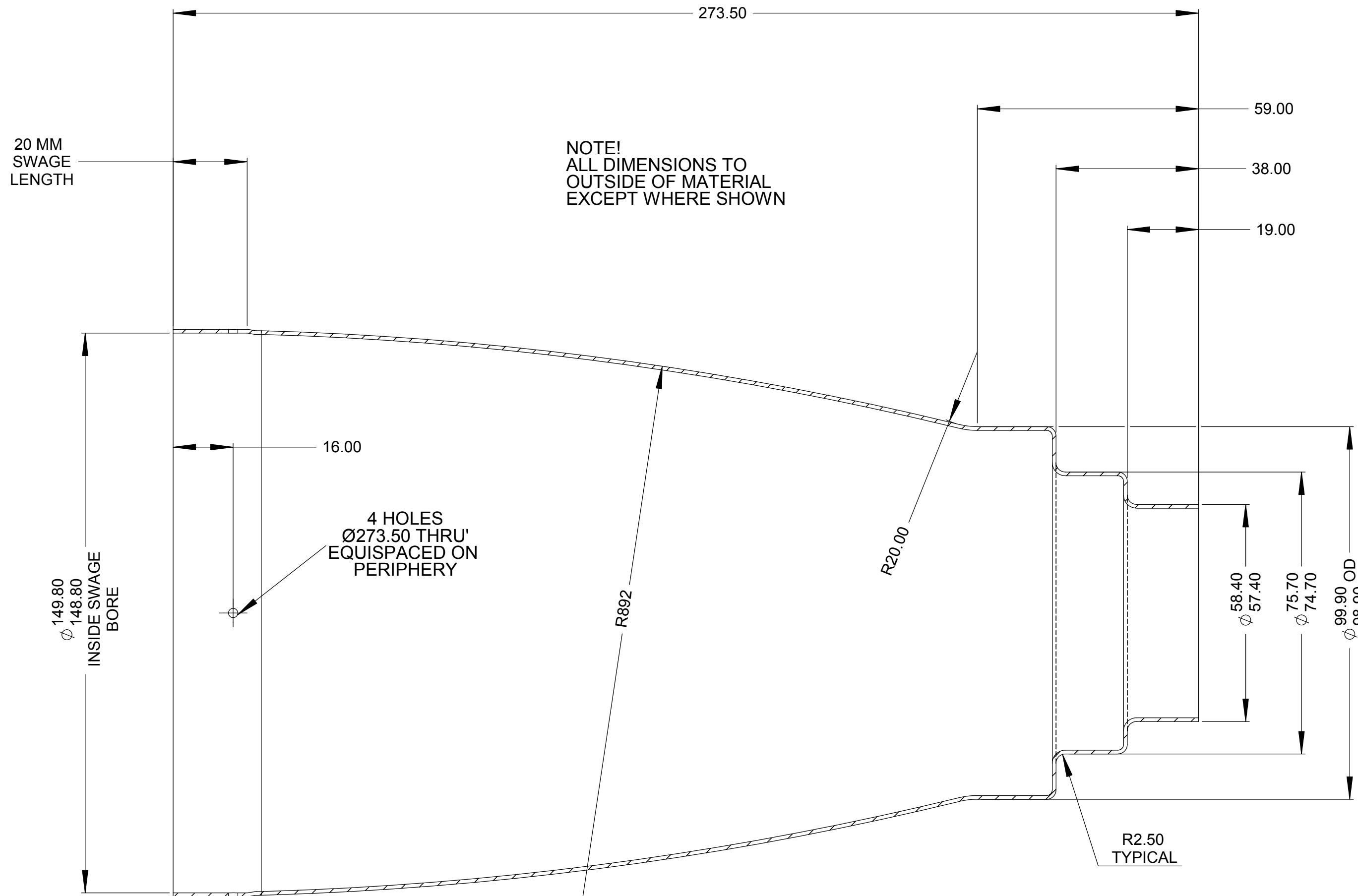
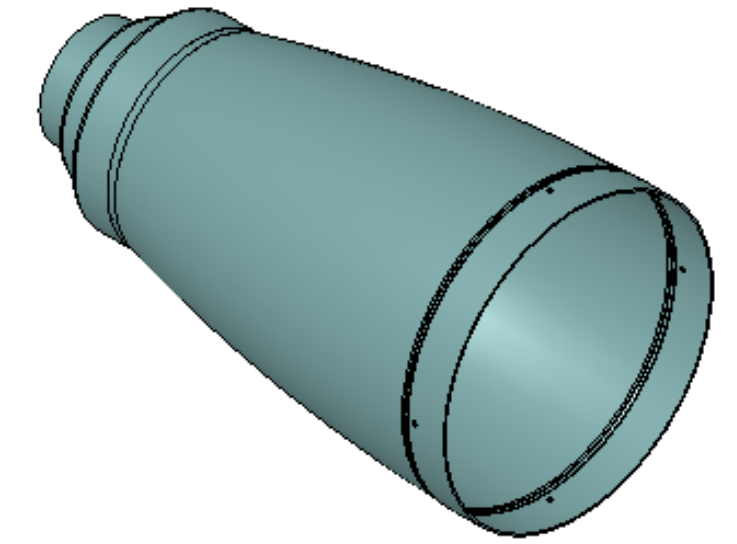

NOTE!  
ALL DIMENSIONS TO  
OUTSIDE OF MATERIAL  
EXCEPT WHERE SHOWN

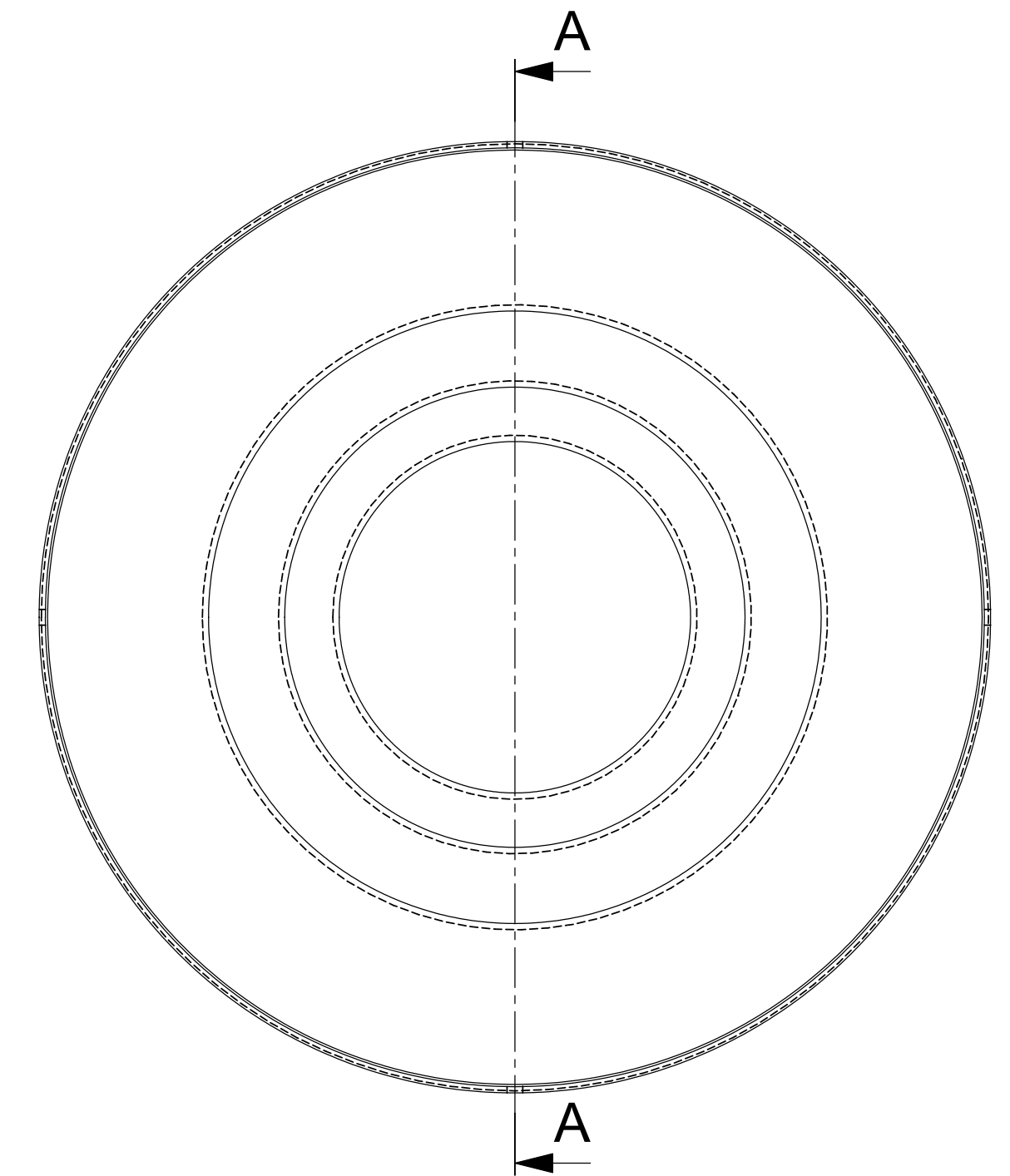

SECOND OPERATION:  
BLUE ANODISE TO BECOME R01E6036

ISSUE	DESCRIPTION	INITIALS	E.C.N. No	DATE
01	ORIGINAL ISSUE	AGL	ECN *****	19-4-04

ALL DIMENSIONS IN MILLIMETRES		
TOLERANCES (AT 20°C) UNLESS OTHERWISE STATED		
NOMINAL LINEAR DIMENSIONS		
OVER-INCL	<0.0	0.00
0-250	± 1.00	± 0.15
250-1000	± 1.50	± 0.20
1000 PLUS	± 2.50	± 0.30
HOLES H14 TO BS4500 1985		
THREADS 6H/6g TO BS3643 1981 - METRIC COARSE		
BSP THREADS TO BS2779 MED FIT		
SURFACE FINISHES		ANG DIMS
MILLING	N8	± 0.5°
TURNING	N7	
GRINDING	N6	

THIS DRAWING IS A PRIVATE AND CONFIDENTIAL COMMUNICATION

REMOVE ALL BURRS AND SHARP EDGES UNLESS OTHERWISE STATED

Unit 5  
121 London Rd  
Marks Tey  
Colchester  
Essex  
CO6 1EB  
www.reverie.ltd.uk  
01206 213001

DRAWN	APP	Title
AGL		DAYTONA 230 'TT' CANNISTER
DATE		58/75/100MM STEPPED EXIT
FINISH		MATERIAL 16 SWG AL.AL.
BLUE ANOD.		Matl.Stk Code 'O'GRADE AL.AL.1050A
SCALE	1:1	DRG. No. R01E6035
Weight		