

## MULSANNE C/ XC/ XRC FITTING INSTRUCTIONS

### LOTUS:A340/ GM:931 TYPE SUB-FRAMES 340R, EXIGE S1 SPORT, AND VXR220



Mulsanne C



XC



XRC

## INTRODUCTION

Mulsanne C/ XC/ XRC are twin skin carbon seats developed for applications where light weight and extreme stiffness are of priority, both the front and back of the seats have a high quality Auto-clave moulded gloss finish.

These performance seat's have been specifically developed for the Lotus Elise S1/S2/111R/Federal, Exige S1/S2, 340R and VX/VXR220 range of cars with tailored fitting kits to suit each model (when ordering you should state Lotus/Vauxhall model and chassis VIN no). Due to the compact dimensions of the seat's they have also proven to be an ideal fitment to vehicles with limited cockpit space.

## **WARNING, MOTORSPORT OR DRIVING CAN BE DANGEROUS RESULTING IN DEATH OR PERSONAL INJURY. READ OUR FITTING INSTRUCTIONS CAREFULLY**

This article is sold without warranty expressed or implied. No warranty or representation is made as to this product's ability to protect the user from injury or death. The user assumes that risk. The effectiveness, warranty and longevity of this equipment are directly related to the manner in which it is INSTALLED, USED, and/or MAINTAINED. THE USER ASSUMES THE RISK. Fitment of REVERIE PRODUCTS TO AUTOMOBILES THAT ARE SUBJECT TO A MANUFACTURER'S WARRANTY MAY VOID THE MANUFACTURER'S WARRANTY AND THE VEHICLES ABILITY TO MEET EMISSION OR OTHER TRANSPORT REGULATIONS. By purchasing this product and opening the packaging, purchasers expressly acknowledge, understand and agree that they take , select and purchase these REVERIE products from REVERIE, its affiliates, distributors, and agents ( collectively, REVERIE) "as is" and "with all faults".

The entire risk as to the quality and performance of these REVERIE parts is with the purchasers. Should the goods prove defective following their purchase; the purchasers assume the entire cost for all necessary servicing or repair or any resulting liability. Working on your car can be a dangerous activity. If you are unsure of what you are doing, please leave mechanical or Safety critical work to a skilled mechanic.

We take no responsibility for the incorrect use and / or installation of REVERIE products.

[WWW.REVERIE.LTD.UK](http://WWW.REVERIE.LTD.UK)

## **INDEX**

### **PAGE**

<b>3</b>	<b>UV-PROTECTION</b>
<b>3</b>	<b>PART NUMBER IDENTIFICATION</b>
<b>4</b>	<b>LOTUS:A340/ GM:931 TYPE SUB-FRAME GENERAL INFORMATION.</b>
<b>5</b>	<b>FITTING KIT CONTENTS</b>
<b>6</b>	<b>FITTING INSTRUCTIONS</b>

## UV-PROTECTION

Please Note Epoxy Pre-preg products are not UV stable. Texallium products are particularly liable and can yellow in only 2 – 6 weeks. The epoxy resin will 'yellow' with prolonged exposure to UV radiation and material strength properties will slowly deteriorate. We recommend exterior products or those exposed to constant UV are either colour painted or at least Lacquered. We use predominately 2K car lacquers of medium solids, the DBS range has been found very suitable, although people have had equally good results with Urethanes varnishes and epoxy clear coats.

The surface should be sanded with 180, 240 then 320 grit and a cleaning solvent used to remove grease or dirt prior to paint application. Several coats may be required (normally 3 to 4 light coats) to avoid pin-holing, common with painting composite products. Pin holes may be dubbed in carefully with a brush, then wet flatted for a final application of 3 thin coats. **Let air dry only**, you may stove the paint at 70'c once fully air dried.

## PART NUMBER IDENTIFICATION

Reverie part numbers are in red eg **R01SI6002A**

Lotus part numbers are in green eg **A111V0012J**

## LOTUS:A340/ GM:931 TYPE SUB-FRAME GENERAL INFORMATION.

The sub frames found in these vehicles are ideal fitment for the ReVerie Mulsanne seats offering double shear rear mounts and slotted front cross brace therefore offering secure location of 4/5/6 point harnesses.

The owner should refer to the MSA blue book for the correct instillation of harnesses for competition.

### Part Numbers

#### 340R/Exige S1 sport

#### VXR 220

RHD	<b>A340V0009J</b>	Lotus Adjustable driver's side
LHD	<b>A340V0010J</b>	Lotus Adjustable driver's side
RHD	<b>A340V0007F</b>	Lotus Fixed passenger side
LHD	<b>A340V0008F</b>	Lotus Fixed passenger side
RHD	<b>93184421</b>	GM Adjustable driver's side
RHD	<b>93184422</b>	Lotus Fixed passenger side

A340 type sub frames shown, the \* insert shows the outside of the Elise S1/S2 Exige S1 C111 type sub-frames having a single shear bracket without facility for lap belt anchorage.

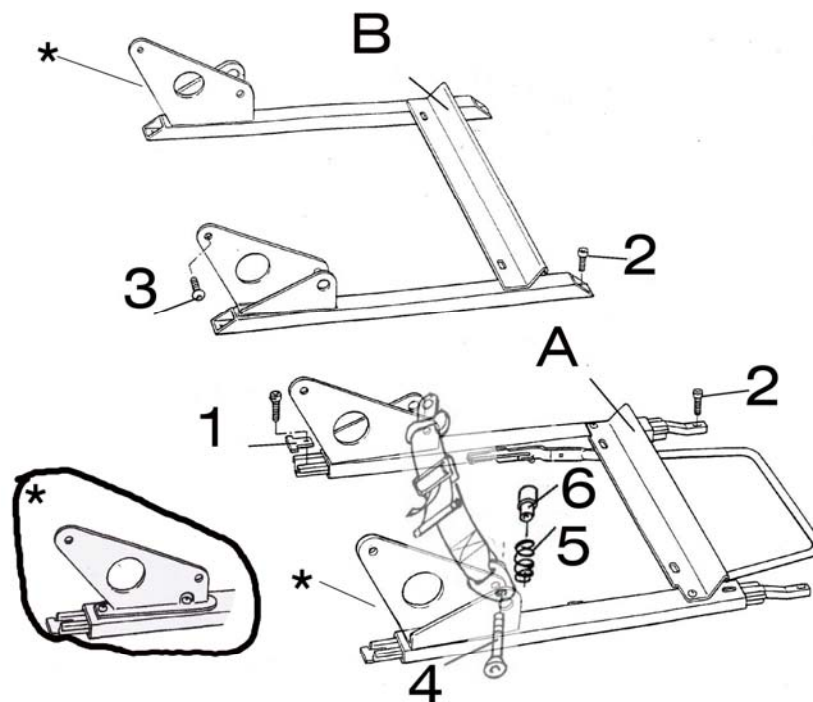

Sliding or fixed lotus Exige/Elise S1/S2 or 340R/Exige sport sub frames are available from a lotus dealer if required.

## FITTING KIT CONTENTS

### MULSANNE C/ XC/ XRC TO LOTUS:A340/ GM:931 TYPE SUB-FRAMES

#### 340R, EXIGE S1 SPORT, and VXR220

Suitable for 4/5/6 point Harnesses on Road/track day cars, see MSA blue book for race cars.

#### Drivers/Passengers side

##### Rear

2 \* Bolt Cap head M8 \* 20mm (12.9 spec)

2 \* Washer Penny M8

2 \* Spacer nylon 5mm M8

(R01SI6048A)

##### Anchor

2 \* Bolt Lotus spec double sheer (long) 7/16 \* 43mm

2 \* Spacer Lotus spec steel double sheer 7/16

2 \* Spacer nylon 5mm 7/16

(R01SI6049A)

##### Front

2 \* Nuts M8

2 \* Washers small OD M8

# FITTING INSTRUCTIONS

## SEAT AND SUBFRAME REMOVAL

- A. Remove existing seats and sub frames from car by undoing the four bolts per sub frame attaching sub frames to chassis (retain bolts).
- B. Remove the seats from the sub frames by undoing the six retaining bolts, 2\*M8 bolts at the rear (discard), 2\*Lotus spec shanked 7/16 seat belt bolts, spacers and spring (retain all), 2\*M8 nuts underneath front of seat (retain).

## FITTING CARBON SEAT TO STD SUB-FRAMES

(Harnesses and std seat belts)

A.

Place the seat on the sub-frame and thread on the retained front M8 nuts and washers, leave loose for the moment to allow the seat a little float.

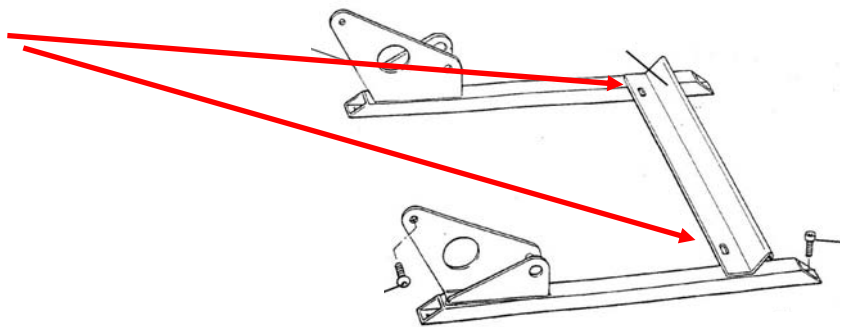

B.

Slide the 7/16 nylon spacers between the seat and sub frame, then re-install the 7/16 bolt's and spacers passing them through the nylon spacers (and seat belt eyes) lightly threading them into the seat. Leave loose for the moment to allow the seat a little float.

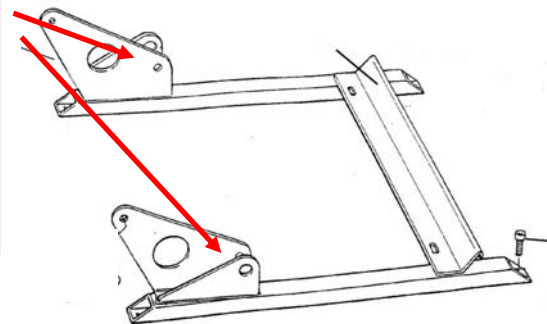

C.

Slide the M8 nylon spacers between the seat and sub frame and insert the two M8\*20mm bolts and washers provided and tighten. The rest of the retaining bolts can now be tightened including the sub-frame side brkt's and cross brace.

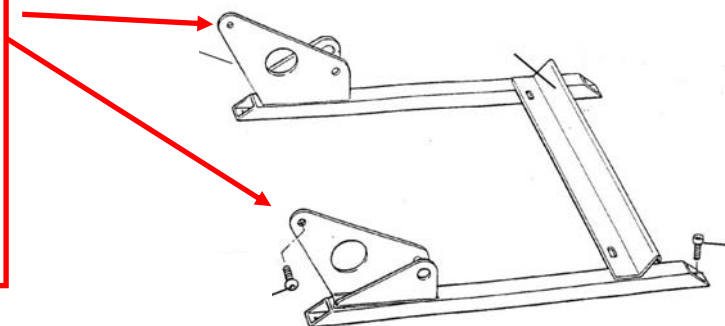

D.

If using OEM 340R harness belts (A340U6005S) a crutch strap is included the steel bar mounts under the sub frame and sits over the M8 studs under the front of the seat. If using another harness either 5 or 6 point then the straps should be taken through the seat and to a secure fixing on the chassis.



E. The seats and sub-frames can now be reinstalled into the car, the passenger side can be bolted straight in, the drivers side should be bolted in loosely to the chassis and the seat ran back and for on the sub-frame runners several times until it runs smooth, the sub frame to chassis bolts can then be tightened.



MULSANNE C FITTED TO LOTUS 340R