

## MULSANNE C/ XC/ XRC FITTING INSTRUCTIONS

### C111 TYPE SUB-FRAMES

**ELISE S1 (std), ELISE S2 (pre VIN:72400),  
ELISE 111R (pre VIN:32403),  
EXIGE S1 (std), EXIGE S2 (pre VIN:82395).**



Mulsanne C



XC



XRC

## INTRODUCTION

Mulsanne C/ XC/ XRC are twin skin carbon seats developed for applications where light weight and extreme stiffness are of priority, both the front and back of the seats have a high quality Auto-clave moulded gloss finish.

These performance seat's have been specifically developed for the Lotus Elise S1/S2/111R/Federal, Exige S1/S2, 340R and VX/VXR220 range of cars with tailored fitting kits to suit each model (when ordering you should state Lotus/Vauxhall model and chassis VIN no). Due to the compact dimensions of the seat's they have also proven to be an ideal fitment to vehicles with limited cockpit space.

## **WARNING, MOTORSPORT OR DRIVING CAN BE DANGEROUS RESULTING IN DEATH OR PERSONAL INJURY.**

### **READ OUR FITTING INSTRUCTIONS CAREFULLY**

This article is sold without warranty expressed or implied. No warranty or representation is made as to this product's ability to protect the user from injury or death. The user assumes that risk. The effectiveness, warranty and longevity of this equipment are directly related to the manner in which it is INSTALLED, USED, and/or MAINTAINED. THE USER ASSUMES THE RISK. Fitment of REVERIE PRODUCTS TO AUTOMOBILES THAT ARE SUBJECT TO A MANUFACTURER'S WARRANTY MAY VOID THE MANUFACTURER'S WARRANTY AND THE VEHICLES ABILITY TO MEET EMISSION OR OTHER TRANSPORT REGULATIONS. By purchasing this product and opening the packaging, purchasers expressly acknowledge, understand and agree that they take , select and purchase these REVERIE products from REVERIE, its affiliates, distributors, and agents ( collectively, REVERIE) "as is" and "with all faults".

The entire risk as to the quality and performance of these REVERIE parts is with the purchasers. Should the goods prove defective following their purchase; the purchasers assume the entire cost for all necessary servicing or repair or any resulting liability. Working on your car can be a dangerous activity. If you are unsure of what you are doing, please leave mechanical or Safety critical work to a skilled mechanic.

We take no responsibility for the incorrect use and / or installation of REVERIE products.

[WWW.REVERIE.LTD.UK](http://WWW.REVERIE.LTD.UK)

## **INDEX**

<b>PAGE</b>	
<b>3</b>	<b>UV-PROTECTION</b>
<b>3</b>	<b>PART NUMBER IDENTIFICATION</b>
<b>4</b>	<b>C111 TYPE SUB-FRAME GENERAL INFORMATION</b>
<b>5</b>	<b>FITTING KIT CONTENTS</b>
<b>6</b>	<b>FITTING INSTRUCTIONS</b>

## UV-PROTECTION

Please Note Epoxy Pre-preg products are not UV stable. Texallium products are particularly liable and can yellow in only 2 – 6 weeks. The epoxy resin will 'yellow' with prolonged exposure to UV radiation and material strength properties will slowly deteriorate. We recommend exterior products or those exposed to constant UV are either colour painted or at least Lacquered. We use predominately 2K car lacquers of medium solids, the DBS range has been found very suitable, although people have had equally good results with Urethanes varnishes and epoxy clear coats.

The surface should be sanded with 180, 240 then 320 grit and a cleaning solvent used to remove grease or dirt prior to paint application. Several coats may be required (normally 3 to 4 light coats) to avoid pin-holing, common with painting composite products. Pin holes may be dubbed in carefully with a brush, then wet flatted for a final application of 3 thin coats. **Let air dry only**, you may stove the paint at 70'c once fully air dried.

## PART NUMBER IDENTIFICATION

Reverie part numbers are in red eg **R01SI6002A**

Lotus part numbers are in green eg **A111V0012J**

## **C111 TYPE SUB-FRAME GENERAL INFORMATION.**

Reverie Ltd recommend The Elise S1 (std), Elise S2 (pre VIN:72400), Exige S1 (std) and Exige S2 (pre VIN:82395) type sub frame's should only be used with conventional type seat belts, and **not 4/5/6 point harnesses**, due to the single shear anchoring on the out side of the sub frame. However ReVerie Ltd manufactures a conversion kit that modifies the above mentioned drivers side sub frame's to 340R (type A340) spec, allowing the safe fitment of 4/5/6 point harnesses. The passenger side sub-frame should be replaced with the type A340 fixed sub frame when harnesses are to be used, A full passenger side type A340 sub-frame kit is available from ReVerie Ltd.

**The owner should refer to the MSA blue book for the correct instillation of harnesses for competition.**

### **Part Numbers**

**Elise S1(std), Elise S2 (pre VIN:72400)**

**Exige S1(std), Exige S2 (pre VIN:82395)**

RHD **C111V0012J** Adjustable driver's side (**std seatbelt only**)

LHD **C111V0011J** Adjustable driver's side (**std seatbelt only**)

RHD **C111V0013F** Fixed passenger side (**std seatbelt only**)

LHD **C111V0014F** Fixed passenger side (**std seatbelt only**)

### **C111 to A340 spec sub-frame conversion kits**

Drivers side conversion kit

RHD **R01SI0040A**

LHD **R01SI0054A**

Passenger side 340R sub-frame kit

RHD **R01SI0023A**

LHD **R01SI0025A**



Drivers side conversion kit shown

## FITTING KIT CONTENTS

### MULSANNE C/ XC/ XRC TO C111 TYPE SUB-FRAMES

**ELISE S1 (std), ELISE S2 (pre VIN:72400),**

**EXIGE S1 (std), EXIGE S2 (pre VIN:82395).**

Standard seat belts only

**GREEN = FITTING KIT CONTENTS SUPPLIED BY ReVerie Ltd.**

**RED = RETAINED FROM OLD SEAT REMOVAL**

#### Passengers side

Rear

2 \* Bolt Cap head M8 \* 20mm (12.9 spec)

2 \* Washer Penny M8

2 \* Spacer nylon 5mm M8

(R01SI6048A)

Anchor

1 \* Bolt Lotus spec double sheer (long) 7/16 \* 43mm

(R01SI6037A)

1 \* Bolt Single sheer 7/16 \* 38mm

1 \* Spacer Lotus spec steel double sheer 7/16

1 \* Spacer Lotus spec steel single sheer 7/16

2 \* Spacer nylon 5mm 7/16

(R01SI6049A)

Front

2 \* Nuts M8

2 \* Washers small OD M8

## Drivers side

### Rear

2 \* Bolt Cap head M8 \* 20mm (12.9 spec)

2 \* Washer Penny M8

### Anchor

1 \* Bolt Lotus spec double sheer (long) 7/16 \* 43mm (R01SI6037A)

1 \* Bolt Single sheer 7/16 \* 38mm

1 \* Spacer Lotus spec steel double sheer 7/16

1 \* Spacer Lotus spec steel single sheer 7/16

### Front

2 \* Nuts M8

2 \* Washers small OD M8

## PASSENGER SIDE FITTING INSTRUCTIONS

### LOTUS SEAT AND SUBFRAME REMOVAL

- A. Remove existing seats and sub frames from car by undoing the four bolts per sub frame attaching sub frames to chassis (retain bolts).
- B. Remove the seats from the sub frames by undoing the six retaining bolts, 2\*M8 bolts at the rear (discard), 1\*7/16 hex head out-side seat belt bolt (discard), 1\* Lotus spec shanked 7/16 in-side seat belt bolt (discard), spacer (retain) and spring (retain), 2\* M8 nuts underneath front of seat (retain).

### FITTING CARBON SEAT TO STD SUBFRAMES (**STD SEAT BELTS ONLY**)

A.

Drill out the rear m8 bolt holes to 10mm. This will aid fitment and reduce the possibility of distortion of the sub-frame.

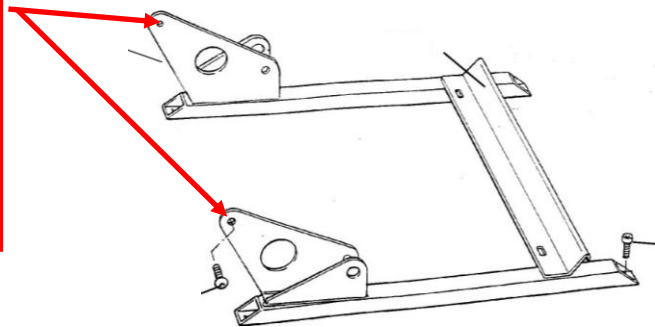

B.

Place the seat sub frame in the car and loosely position the support spars using the 4 chassis fixing locations(M8\*16mm Socket Head). Tighten the cross member bolts (M8 \* 12mm Button Head) to fix the sub frame in position. Then remove the Sub-frame from the car

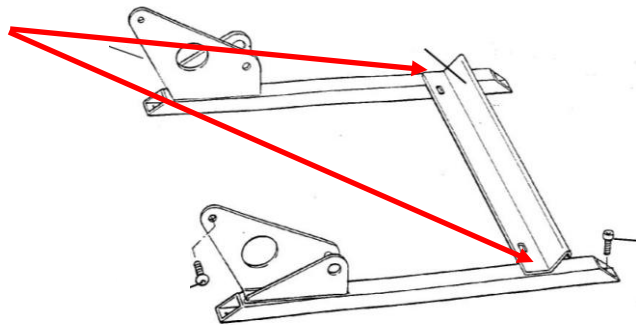

C.

Place the seat on the sub-frame and thread on the retained front M8 nuts and washers, leave loose for the moment to allow the seat a little float.

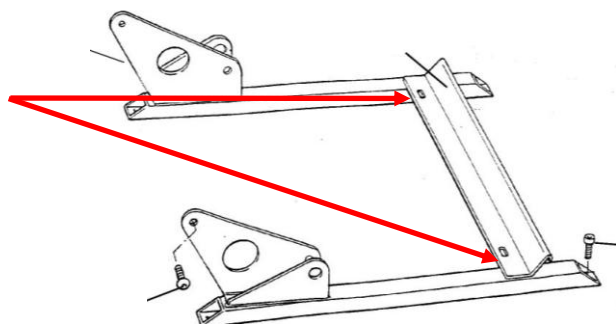

D.

Slide the 7/16 nylon packing spacers between the seat and sub frame then insert the provided hex head 7/16 outside bolt and inside 7/16 lotus bolt and retained steel spacers, passing the bolts through the nylon packing spacers (and lap belt eyes) and lightly threading them into the seat, leave loose for the moment to allow the seat a little float.

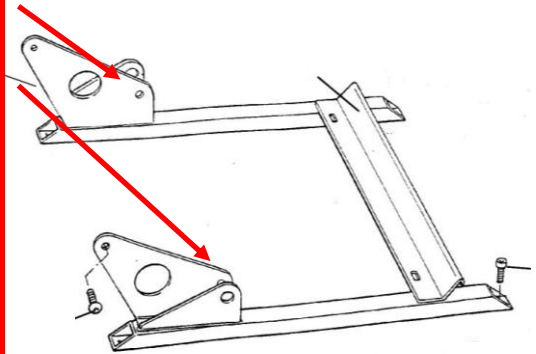

E.

Slide the M8 nylon spacers between the seat and sub frame and insert the two M8\*20mm bolts and washers provided and tighten. The rest of the retaining bolts can now be tightened.

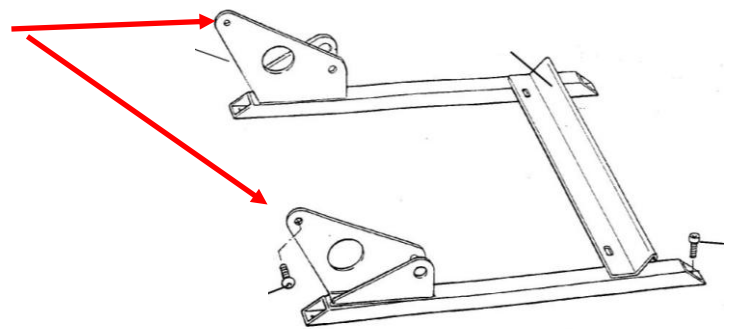

F. The seats and sub-frames can now be reinstalled into the car, the passenger side can be bolted straight in, the sub frame to chassis bolts can then be tightened

## DRIVER SIDE FITTING INSTRUCTIONS

### LOTUS SEAT AND SUBFRAME REMOVAL

- A. Remove existing seats and sub frames from car by undoing the four bolts per sub frame attaching sub frames to chassis (retain bolts).
- B. Remove the seats from the sub frames by undoing the six retaining bolts, 2\*M8 bolts at the rear (discard), 1\*7/16 hex head out-side seat belt bolt (discard), 1\* Lotus spec shanked 7/16 in-side seat belt bolt (discard), spacer (retain) and spring (retain), 2\* M8 nuts underneath front of seat (retain).

### FITTING CARBON SEAT TO STD SUBFRAMES (STD SEAT BELTS ONLY)

A.

Drill out the rear m8 bolt holes to 10mm. This will aid fitment and reduce the possibility of distortion of the sub-frame.

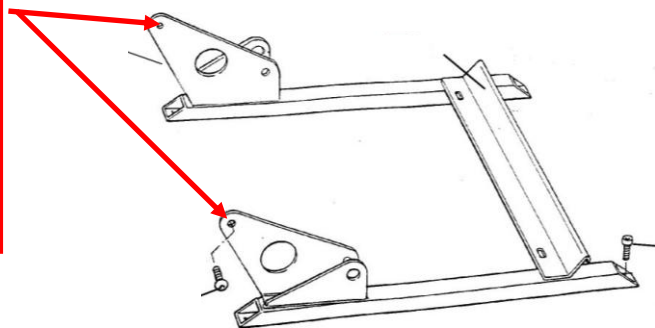

B.

Place the seat sub frame in the car and loosely position the support spars using the 4 chassis fixing locations. Tighten the cross member bolts to fix the sub frame in position (M8\*12 Button head). Then remove the Sub-frame from the car

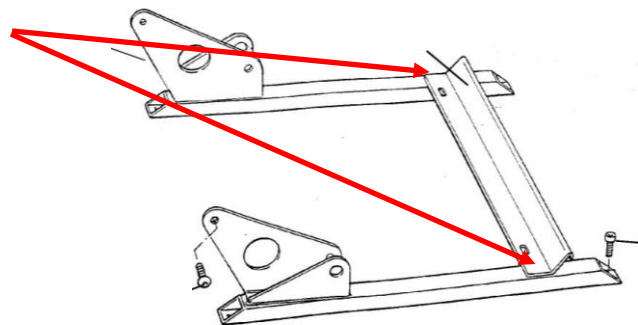

C.

Place the seat on the sub-frame and thread on the retained front M8 nuts and washers, leave loose for the moment to allow the seat a little float.

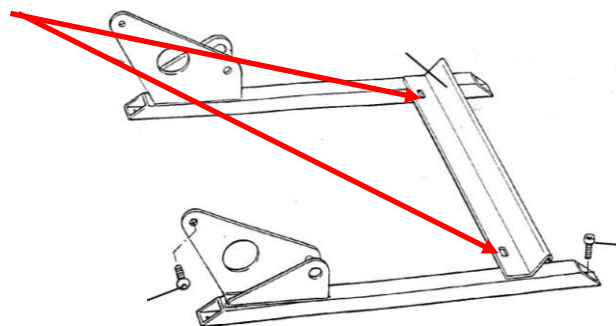

D.

Insert the provided hex head 7/16 out side bolt and inside 7/16 lotus bolt and retained steel spacers, passing the bolts through the bracket and lap belt eyes and lightly threading them into the seat, leave loose for the moment to allow the seat a little float.

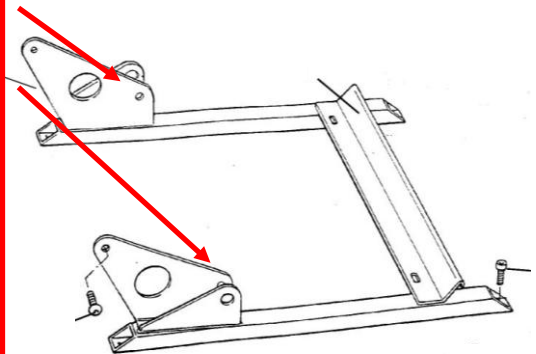

E.

Insert the two M8\*20mm bolts and washers provided and tighten. The rest of the retaining bolts can now be tightened.

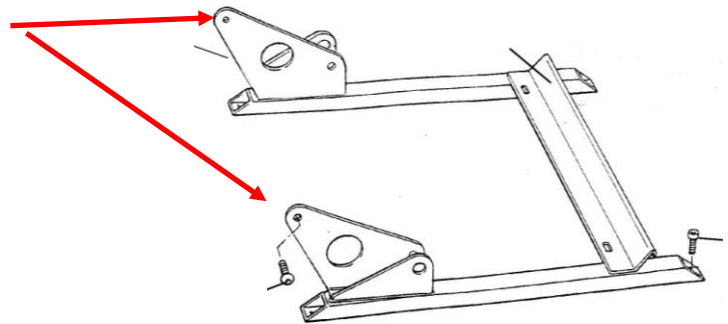

F. The seats and sub-frames can now be reinstalled into the car, the passenger side can be bolted straight in, the drivers side should be bolted in loosely to the chassis and the seat ran back and for on the sub-frame runners several times until it runs smooth, the sub frame to chassis bolts can then be tightened.

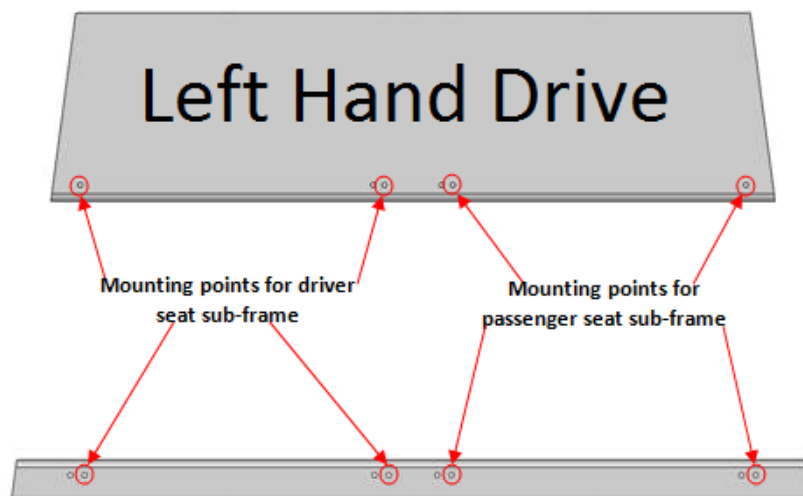
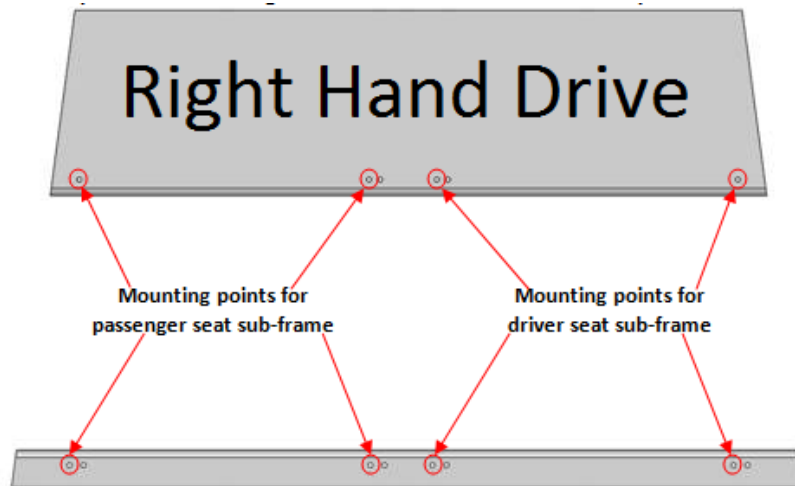

Pay close attention to which holes are used. (RHD shown, LHD is mirror fitment)